

SERIE

E

GUIDED COMPACT CYLINDER

airtec.nl

CARATTERISTICHE TECNICHE - TECHNICAL CHARACTERISTICS

Pressione di esercizio <i>Working pressure</i>	1 ÷ 10 bar (doppio effetto - <i>double acting</i>)
Temperatura di esercizio <i>Working temperature</i>	0 ÷ +80°C (-20°C con aria secca - <i>with dry air</i>)
Versioni - Versions	doppio effetto - <i>double acting</i>
Alesaggi - Bores	∅ 16 - 20 - 25 - 32 - 40 - 50 - 63
Corse - Strokes	vedere tabelle corse standard - <i>see standard stroke tables</i>
Fluido - Fluid	aria compressa filtrata, non lubrificata - <i>compressed filtered, non lubricated air</i>

CARATTERISTICHE COSTRUTTIVE - CONSTRUCTIVE CHARACTERISTICS

① Piastra - Plate	acciaio nichelato - <i>nickel steel</i>
② Stelo di Guida - Guide Rod	acciaio C45 cromato - <i>C45 chromed steel</i>
③ Raschiatore - Wiper	NBR
④ Boccola - Bush	bronzo sinterizzato - <i>sintered bronze</i>
⑤ Corpo - Body	alluminio anodizzato - <i>anodized aluminum</i>
⑥ Guarnizione stelo - Rod Seal	poliuretano - <i>polyurethane</i>
⑦ Testa Anteriore - Front Cover	alluminio anodizzato - <i>anodized aluminum</i>
⑧ Paracolpo - Bumper	NBR
⑨ Stelo - Rod	acciaio C45 cromato - <i>C45 chromed steel</i>
⑩ Pistone - Piston	alluminio - <i>aluminum</i>
⑪ Guarnizione Pistone - Piston Seal	NBR
⑫ Magnete - Magnet	plastroferrite
⑬ Testa posteriore - Rear Cover	alluminio anodizzato - <i>anodized aluminum</i>

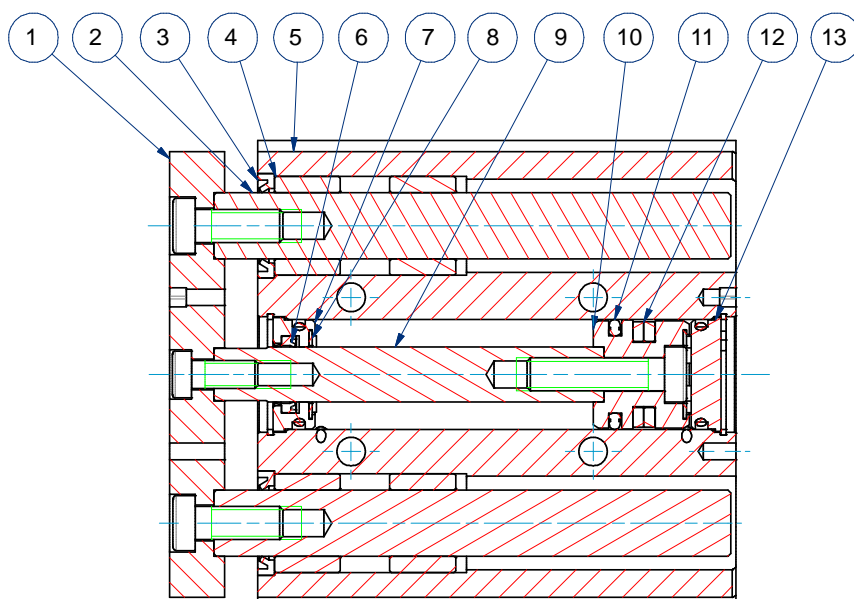

SERIE

E

CHIAVE DI CODIFICA

KEY CODE

E	D	M	016 - 020 - 025 - 032 040 - 050 - 063	050 . 030 .	G S		
			ALESAGGIO - BORE (Ø)	CORSA - STROKE (mm)		OPZIONE - OPTION	
			016 - 020 - 025 - 032 040 - 050 - 063	vedere tabelle corse std see std stroke table		EX ATEX  II 2GD c T4	
			VERSIONE - VERSION			OPZIONE - OPTION	
			con boccole in bronzo with bronze bushes			.S steli-viti-seeger inox SS rod screws-retaining ring	
			S con cuscinetti a ricircolo di sfere with recirculating ball bearings			OPZIONE - OPTION	
			VERSIONE - VERSION			senza ammortizzo pneumatico without pneumatic cushioning	
			M magnetico magnetic			.W con ammortizzo pneumatico with pneumatic cushioning	
			non magnetico non-magnetic			GUARNIZIONI - SEALS	
			VERSIONE - VERSION			GS guarnizioni standard standard seals	
			D doppio effetto double acting			VR guarnizione stelo per alte temperature high temperature rod seal	
			SERIE - SERIES			VA tutte le guarnizioni per alte temperature all seals for high temperature	
			E tubo profilato con cave per sensori profile tube with slots for sensors				

SERIE

E

ESECUZIONI A RICHIESTA - ON REQUEST

Doppia piastra - Double plate

Stelo prolungato (FB) - Extended rod (FB)

ATEX  II 2GD c T4

FORZE TEORICHE DI TRAZIONE (P=6bar)

THEORETICAL FORCES OF TRACTION (P=6bar)

		Ø	016	020	025	032	040	050	063
EDM	SPINTA THRUST	[N]	121	188	295	483	754	1178	1870
	TRAZIONE TRACTION	[N]	90	141	247	415	686	1057	1750

ESEMPI DI FISSAGGIO

FIXING EXAMPLE

MONTAGGIO SUPERIORE
TOP MOUNTING

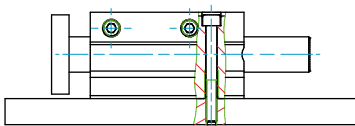

MONTAGGIO INFERIORE
BOTTOM MOUNTING

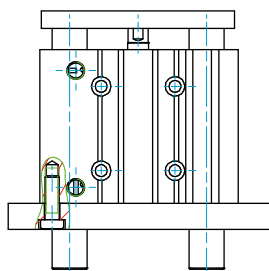

MONTAGGIO LATERALE
SIDE MOUNTING

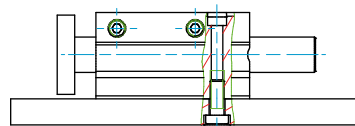

MONTAGGIO TRAMITE
DADO NELLA CAVA A "T"
NUT INSIDE T-SLOT
MOUNTING

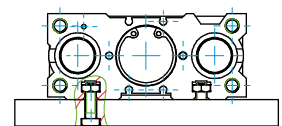

!!! The fixing must be with non-magnetic screws

DIAGRAMMA TEORICO CARICO AMMISSIBILE

THEORETICAL ALLOWABLE LOAD

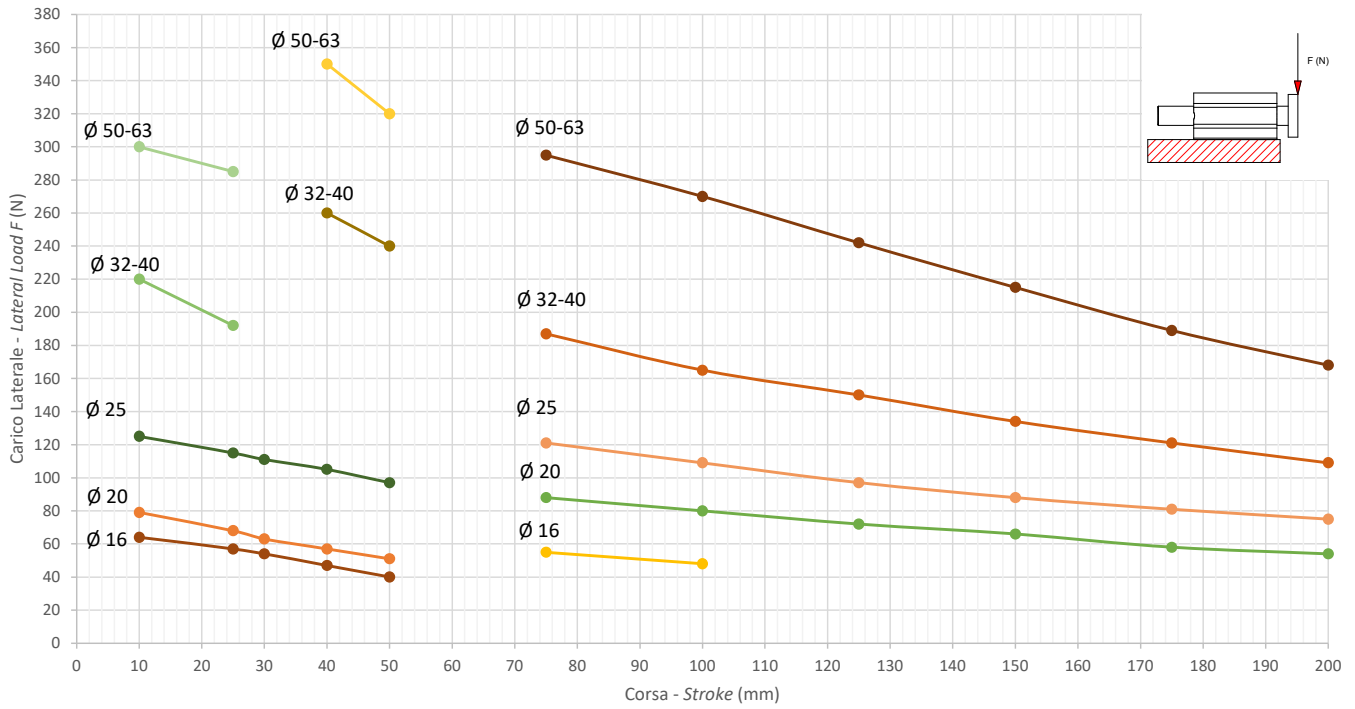

SERIE
E

DIAGRAMMA TEORICO CARICO AMMISSIBILE

THEORETICAL ALLOWABLE LOAD



DIAGRAMMA TEORICO CARICO AMMISSIBILE

EDM-W

THEORETICAL ALLOWABLE LOAD

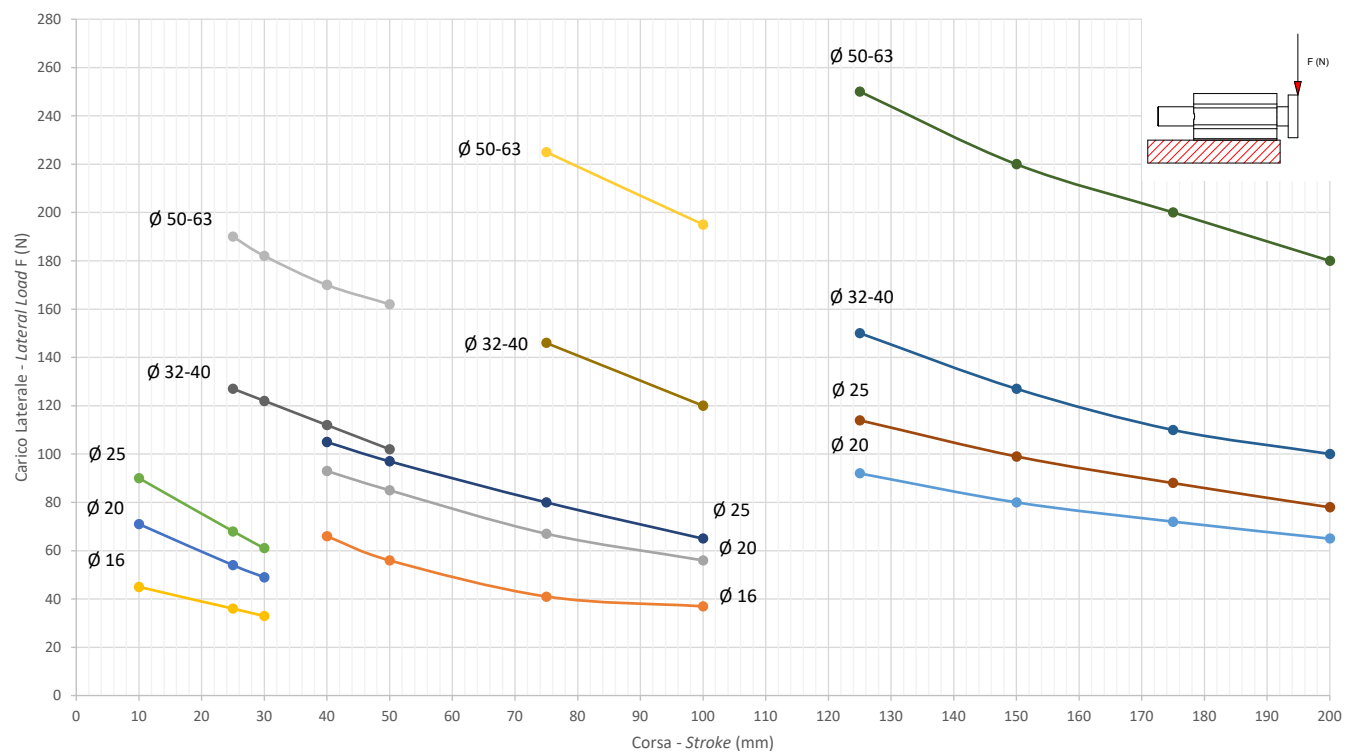
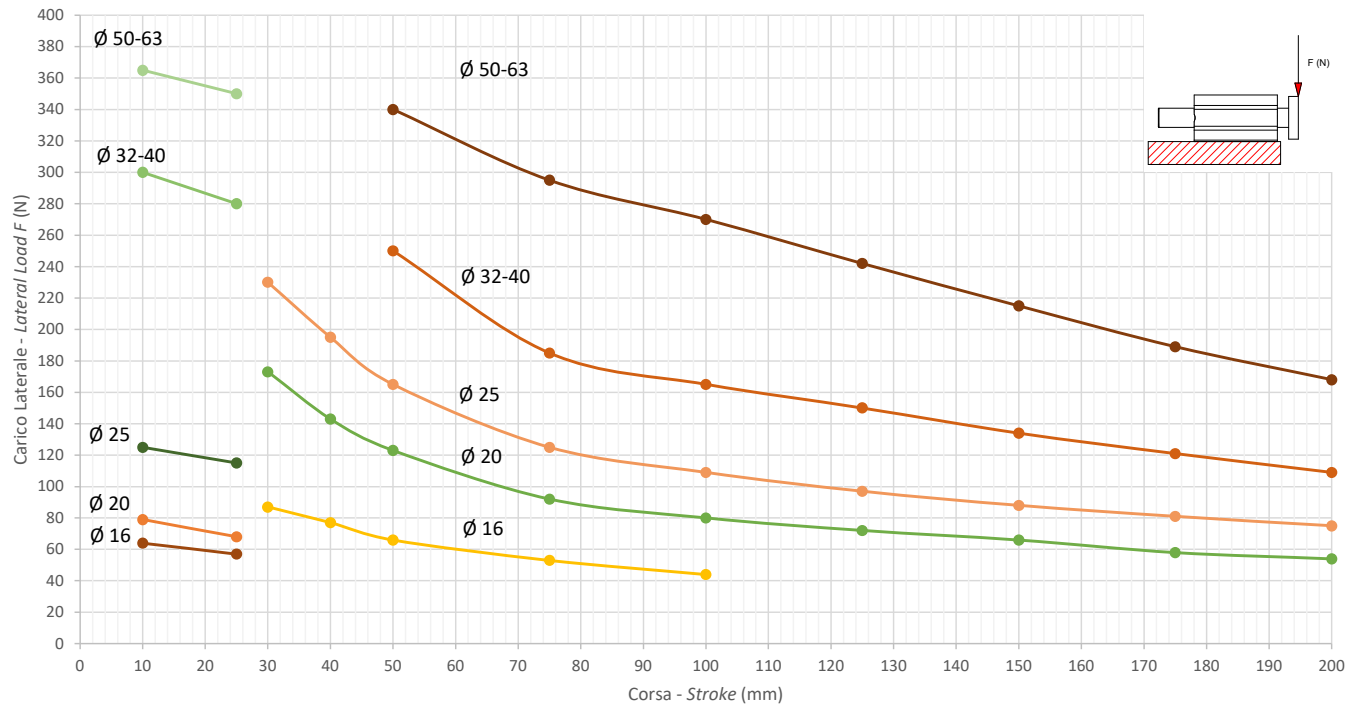

SERIE
E

DIAGRAMMA TEORICO CARICO AMMISSIBILE

EDMS-W

THEORETICAL ALLOWABLE LOAD



DIAGRAMMA TEORICO COPPIA AMMISSIBILE

EDM

THEORETICAL ALLOWABLE TORQUE

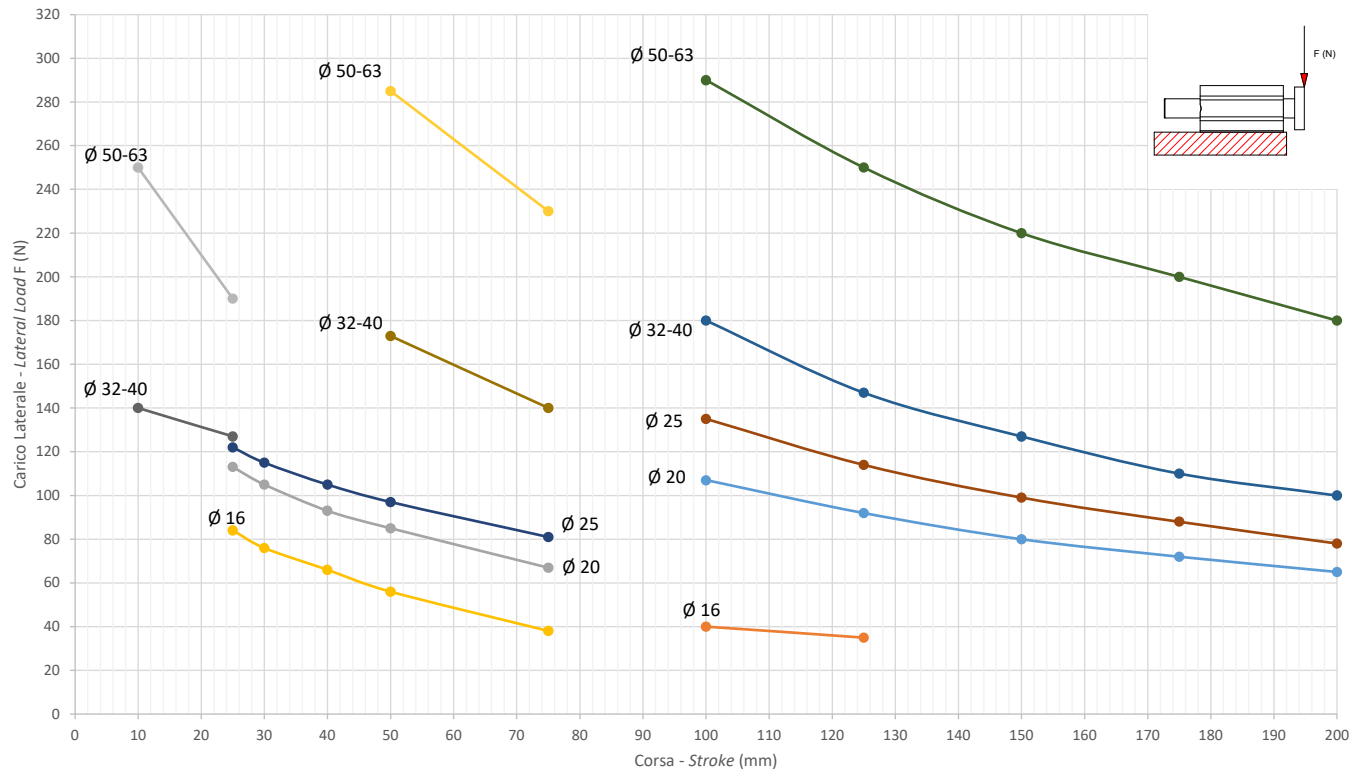
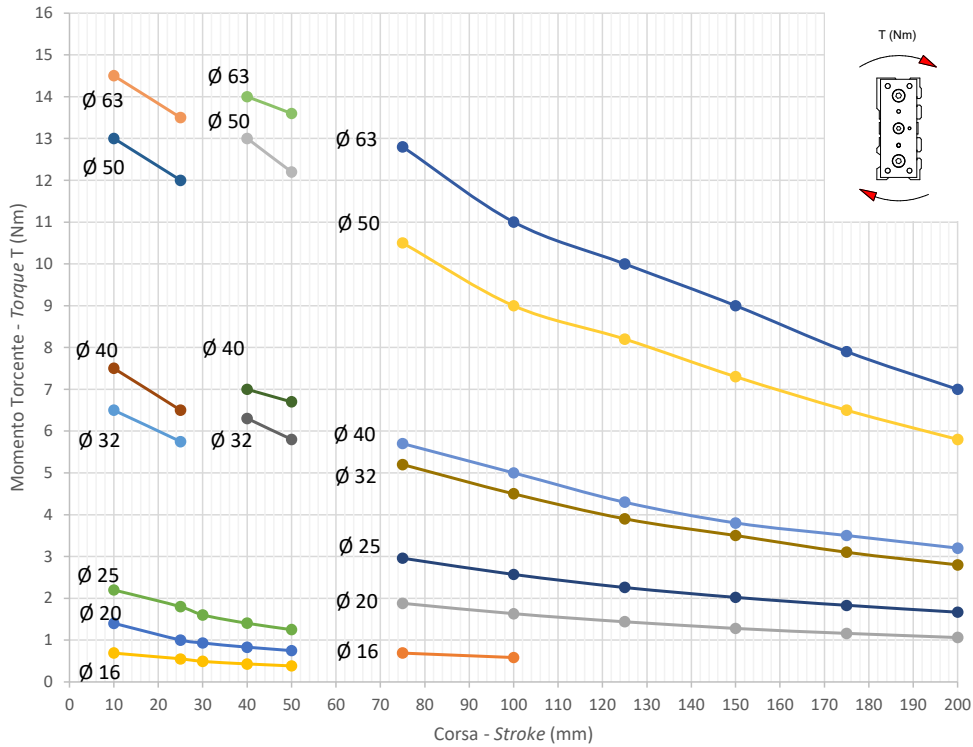

SERIE

E

DIAGRAMMA TEORICO COPPIA AMMISSIBILE

EDMS

THEORETICAL ALLOWABLE TORQUE



DIAGRAMMA TEORICO COPPIA AMMISSIBILE

EDM-W

THEORETICAL ALLOWABLE TORQUE

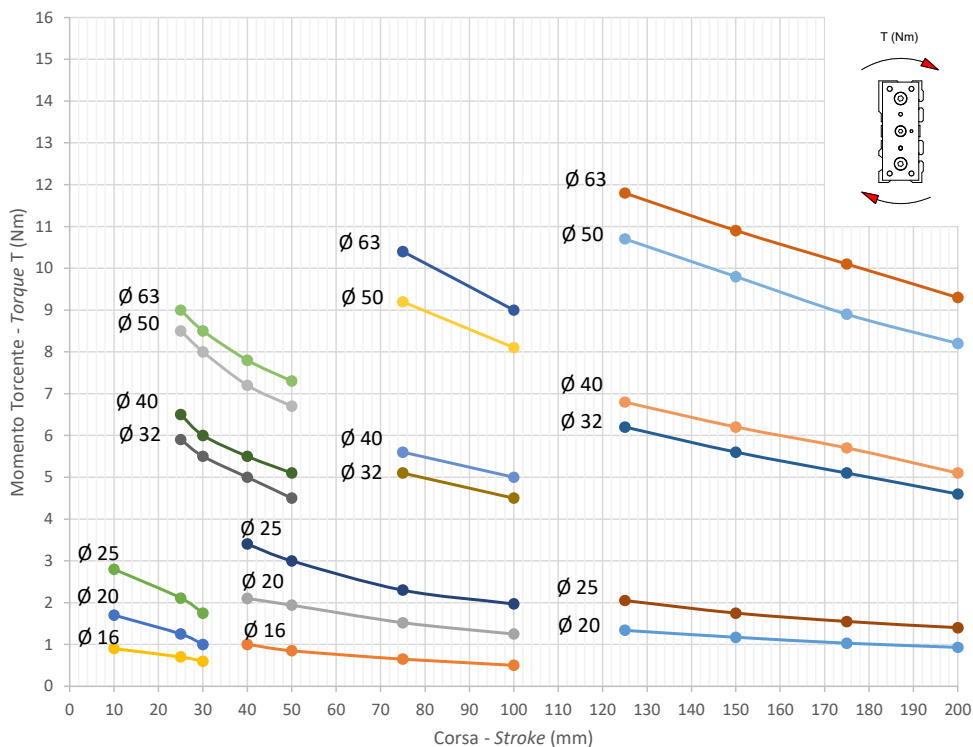
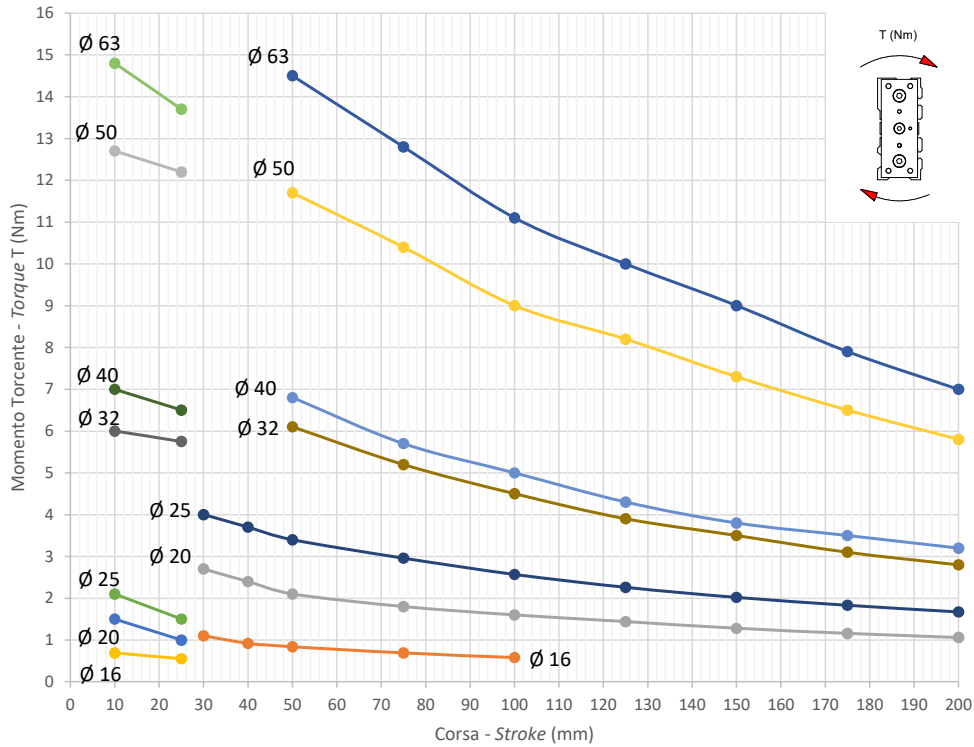

SERIE

E

DIAGRAMMA TEORICO COPPIA AMMISSIBILE

EDMS-W

THEORETICAL ALLOWABLE TORQUE

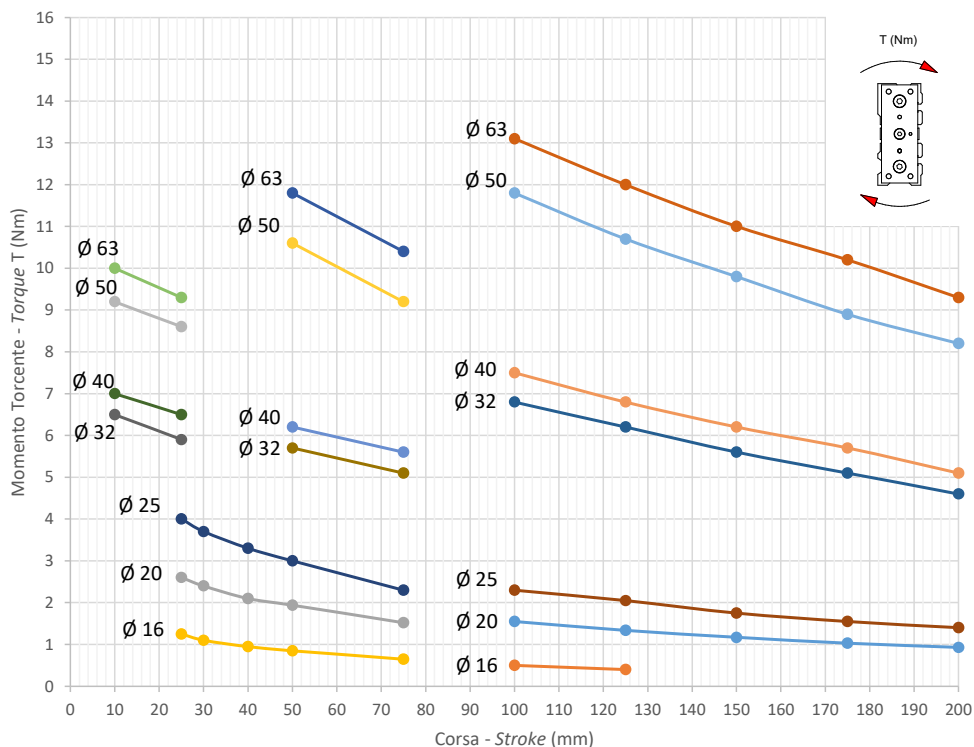

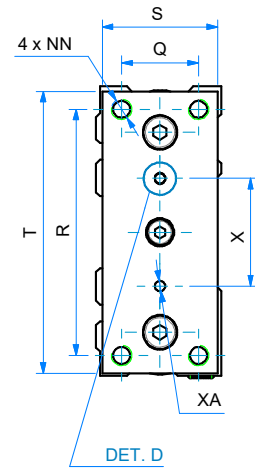
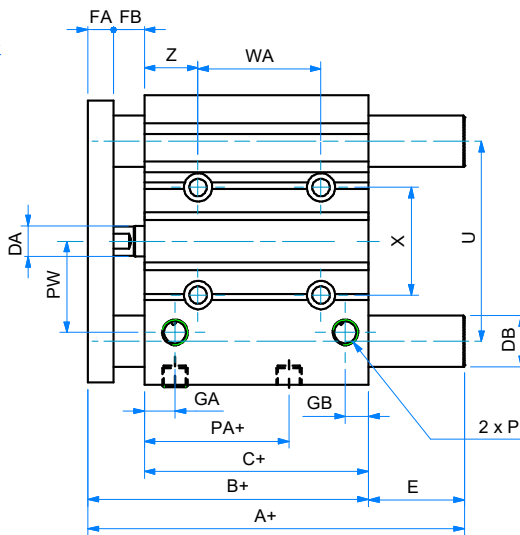
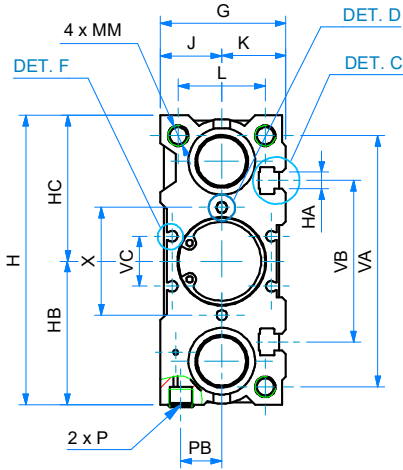
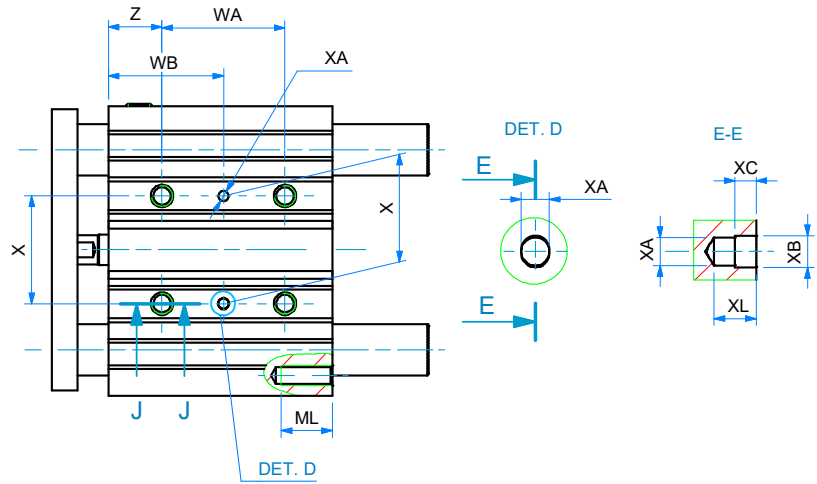
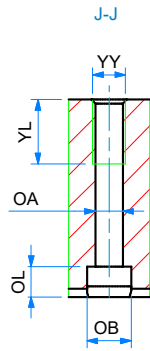
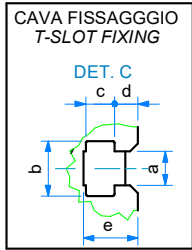
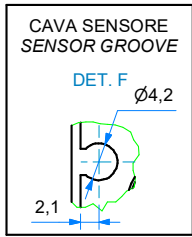
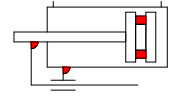

θ	CORSE STANDARD - STANDARD STROKES
016	10 - 20 - 30 - 40 - 50 - 75 - 100
020	20 - 30 - 40 - 50 - 75 - 100 - 125 - 150 - 175 - 200
025	20 - 30 - 40 - 50 - 75 - 100 - 125 - 150 - 175 - 200
032	25 - 50 - 75 - 100 - 125 - 150 - 175 - 200
040	25 - 50 - 75 - 100 - 125 - 150 - 175 - 200
050	25 - 50 - 75 - 100 - 125 - 150 - 175 - 200
063	25 - 50 - 75 - 100 - 125 - 150 - 175 - 200

!!!: Le corse intermedie vengono realizzate con il corpo della corsa standard superiore e con distanziale interno per limitarne la corsa a quella richiesta.
Intermediate strokes are made with the profile of the standard superior stroke and with an internal spacer which limits the stroke to the required one.



DIMENSIONI - DIMENSIONS

CON BOCCHE IN BRONZO - WITH BRONZE BUSH

ø	16	20	25	32	40	50	63
A+ (corsa-stroke 0÷50)	42	53	53,5	97	91	106,5	106,5
A+ (corsa-stroke 75÷200)	64,5	84,5	85	102	102	118	118
B+	46	53	53,5	59,5	66	72	77
C+	33	37	37,5	37,5	44	44	49
ø DA	8	10	10	12	12	16	16
ø DB	10	12	16	20	20	25	25
E (corsa-stroke 0÷50)	0	0	0	37,5	31	34,5	29,5
E (corsa-stroke 75÷200)	18,5	31,5	31,5	42,5	36	46	41
FA	8	10	10	10	10	15	15
FB	5	6	6	12	12	13	13
G	30,5	36,8	42,8	49	55	65	79
GA	11	11,5	11,5	12	15	15	15,5
GB	8	9	10	9	12	12	13,5
H	64	84	94	113	121	149	163
HA	M4	M5	M5	M6	M6	M8	M10
HB	32,5	41,5	46,5	56	60	74	81
HC	32	42,5	47,5	57	61	75	82
J	15	18	21	24	27	32	39
K	15,5	18,8	21,8	25	28	33	40
L	22	24	30	34	40	46	58
MM	M5	M5	M6	M8	M8	M10	M10
ML	12	13	15	16	16	20	22
NN	M5	M5	M6	M8	M8	M10	M10
OA	4,2	5,2	5,2	6,5	6,5	8,5	8,5
OB	8	9,5	9,5	11	11	14	14
OL	4,5	5,5	5,5	7,5	7,5	9	9
P	M5	G1/8	G1/8	G1/8	G1/8	G1/4	G1/4
PA+	15	13,5	12,5	6,5	13	9	13
PB	10	11	14	16	18	21,5	28
PW	19	25	30	35,5	39,5	47	58
Q	16	18	26	30	30	40	50
R	54	70	78	96	104	130	130
S	25	30	40	45	45	60	70
T	62	81	91	110	118	146	158
U	46	54	64	78	86	110	124
VA	56	72	82	98	106	130	142
VB	38	44	50	63	72	92	110
VC	10,5	12,5	15	19,5	25	33	34
WA (corsa-stroke 0÷30)	24	24	24	24	24	24	28
WA (corsa-stroke 40÷100)	44	44	44	48	48	48	52
WA (corsa-stroke 125÷200)	110	120	120	124	124	124	128
WB (corsa-stroke 0÷30)	17	29	29	33	34	36	38
WB (corsa-stroke 40÷100)	27	39	39	45	46	48	50
WB (corsa-stroke 125÷200)	60	77	77	83	84	86	88
X ± 0,02	24	28	34	42	50	66	80
ø XA H9	3	3	4	4	4	5	5
XB	3,5	3,5	4,5	4,5	4,5	6	6
XC	3	3	3	3	3	4	4
XL	6	6	6	6	6	8	8
YY	M5	M6	M6	M8	M8	M10	M10
YL	10	12	12	16	16	20	22
Z	5	17	17	21	22	24	24
a	4,4	5,4	5,4	6,5	6,5	8,5	11
b	7,4	8,4	8,4	10,5	10,5	13,5	17,8
c	3,7	4,5	4,5	5,5	5,5	7,5	10
d	3,5	3,6	3,8	4,5	5	5,5	8
e	6,7	8,6	9	10,5	10,5	14,5	19,5

COMPATTO GUIDATO D.E.M. CON CUSCINETTI A RICIRCOLO DI SFERE

D.A.M. GUIDED COMPACT WITH RECIRCULATING BALL BEARINGS

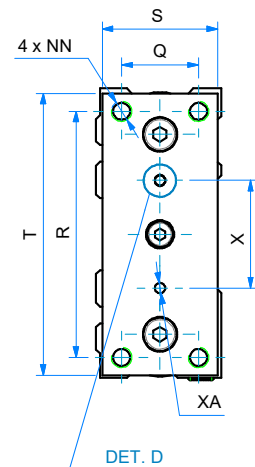
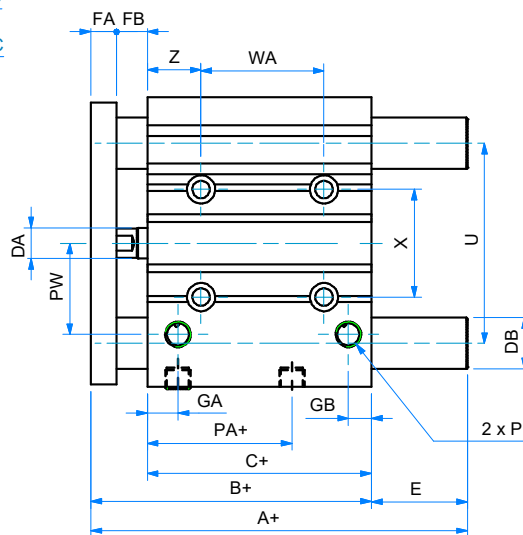
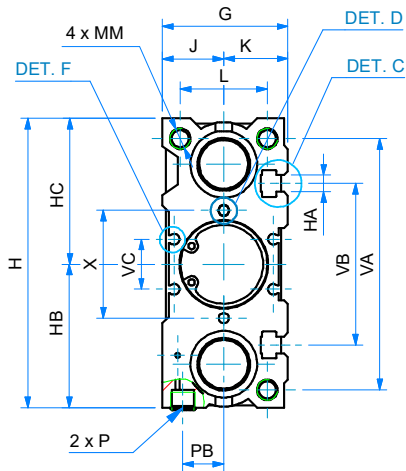
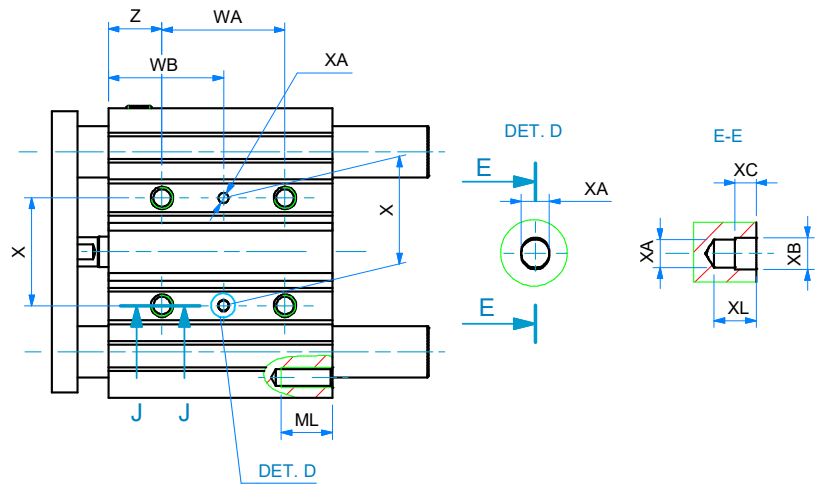
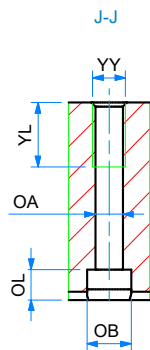
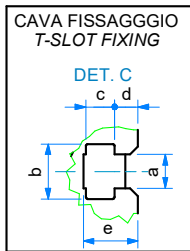
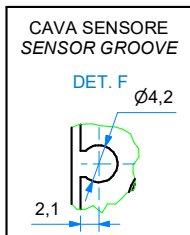
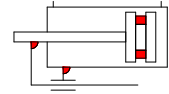

CORSE STANDARD - STANDARD STROKES

016	10 - 20 - 30 - 40 - 50 - 75 - 100
020	20 - 30 - 40 - 50 - 75 - 100 - 125 - 150 - 175 - 200
025	20 - 30 - 40 - 50 - 75 - 100 - 125 - 150 - 175 - 200
032	25 - 50 - 75 - 100 - 125 - 150 - 175 - 200
040	25 - 50 - 75 - 100 - 125 - 150 - 175 - 200
050	25 - 50 - 75 - 100 - 125 - 150 - 175 - 200
063	25 - 50 - 75 - 100 - 125 - 150 - 175 - 200

!!!: Le corse intermedie vengono realizzate con il corpo della corsa standard superiore e con distanziale interno per limitarne la corsa a quella richiesta.

Intermediate strokes are made with the profile of the standard superior stroke and with an internal spacer which limits the stroke to the required one.

DIMENSIONI - DIMENSIONS CON CUSCINETTI A RICIRCOLO DI SFERE - WITH RECIRCULATING BALL BEARINGS

\varnothing	16	20	25	32	40	50	63
A+ (corsa-stroke 0÷30)	49	63	69,5	-	-	-	-
A+ (corsa-stroke 40÷100)	65	80	86	-	-	-	-
A+ (corsa-stroke 125÷200)	-	104	104,5	-	-	-	-
A+ (corsa-stroke 0÷50)	-	-	-	81	81	93	93
A+ (corsa-stroke 75÷100)	-	-	-	98	98	114	114
A+ (corsa-stroke 125÷200)	-	-	-	118	118	134	134
B+	46	53	53,5	59,5	66	72	77
C+	33	37	37,5	37,5	44	44	49
\varnothing DA	8	10	10	12	12	16	16
\varnothing DB	8	12	14	20	20	25	25
E (corsa-stroke 0÷30)	3	10	16	-	-	-	-
E (corsa-stroke 40÷100)	19	27	32,5	-	-	-	-
E (corsa-stroke 125÷200)	-	51	51	-	-	-	-
E (corsa-stroke 0÷50)	-	-	-	21,5	15	21	16
E (corsa-stroke 75÷100)	-	-	-	38,5	32	42	37
E (corsa-stroke 125÷200)	-	-	-	58,5	52	62	57
FA	8	10	10	10	10	15	15
FB	5	6	6	12	12	13	13
G	30,5	36,8	42,8	49	55	65	79
GA	11	11,5	11,5	12	15	15	15,5
GB	8	9	10	9	12	12	13,5
H	64	84	94	113	121	149	163
HA	M4	M5	M5	M6	M6	M8	M10
HB	32,5	41,5	46,5	56	60	74	81
HC	32	42,5	47,5	57	61	75	82
J	15	18	21	24	27	32	39
K	15,5	18,8	21,8	25	28	33	40
L	22	24	30	34	40	46	58
MM	M5	M5	M6	M8	M8	M10	M10
ML	12	13	15	16	16	20	22
NN	M5	M5	M6	M8	M8	M10	M10
OA	4,2	5,2	5,2	6,5	6,5	8,5	8,5
OB	8	9,5	9,5	11	11	14	14
OL	4,5	5,5	5,5	7,5	7,5	9	9
P	M5	G1/8	G1/8	G1/8	G1/8	G1/4	G1/4
PA+	15	13,5	12,5	6,5	13	9	13
PB	10	11	14	16	18	21,5	28
PW	19	25	30	35,5	39,5	47	58
Q	16	18	26	30	30	40	50
R	54	70	78	96	104	130	130
S	25	30	40	45	45	60	70
T	62	81	91	110	118	146	158
U	46	54	64	78	86	110	124
VA	56	72	82	98	106	130	142
VB	38	44	50	63	72	92	110
VC	10,5	12,5	15	19,5	25	33	34
WA (corsa-stroke 0÷30)	24	24	24	24	24	24	28
WA (corsa-stroke 40÷100)	44	44	44	48	48	48	52
WA (corsa-stroke 125÷200)	110	120	120	124	124	124	128
WB (corsa-stroke 0÷30)	17	29	29	33	34	36	38
WB (corsa-stroke 40÷100)	27	39	39	45	46	48	50
WB (corsa-stroke 125÷200)	60	77	77	83	84	86	88
X ± 0,02	24	28	34	42	50	66	80
\varnothing XA H9	3	3	4	4	4	5	5
XB	3,5	3,5	4,5	4,5	4,5	6	6
XC	3	3	3	3	3	4	4
XL	6	6	6	6	6	8	8
YY	M5	M6	M6	M8	M8	M10	M10
YL	10	12	12	16	16	20	22
Z	5	17	17	21	22	24	24
a	4,4	5,4	5,4	6,5	6,5	8,5	11
b	7,4	8,4	8,4	10,5	10,5	13,5	17,8
c	3,7	4,5	4,5	5,5	5,5	7,5	10
d	3,5	3,6	3,8	4,5	5	5,5	8
e	6,7	8,6	9	10,5	10,5	14,5	19,5

COMPATTO GUIDATO D.E.M. CON BOCCOLE IN BRONZO AMMORTIZZATO

D.A.M. GUIDED COMPACT WITH BRONZE BUSHES CUSHIONED

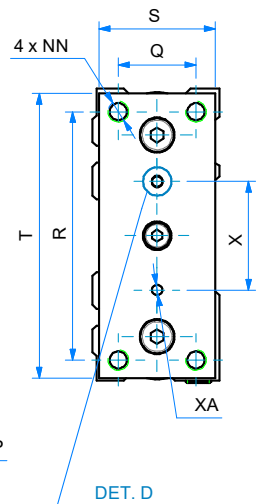
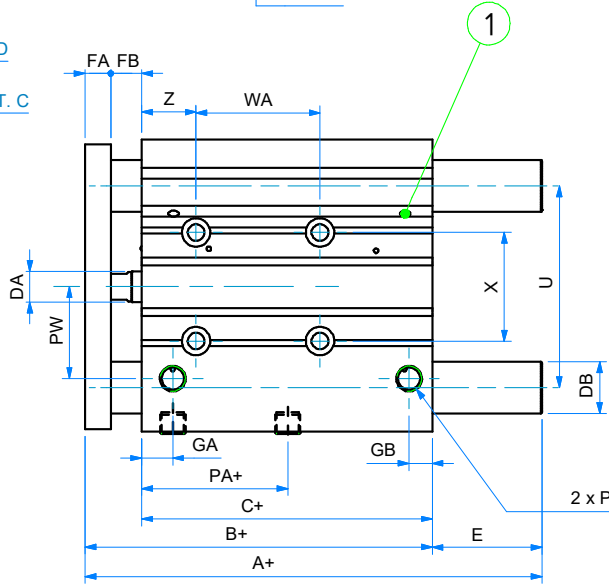
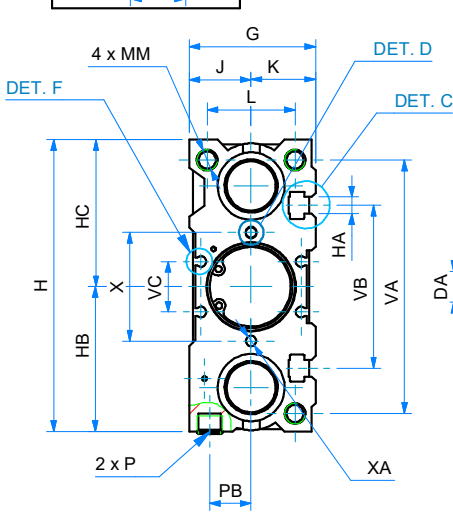
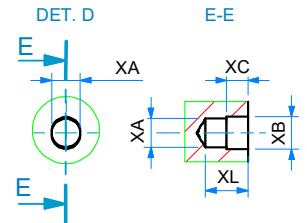
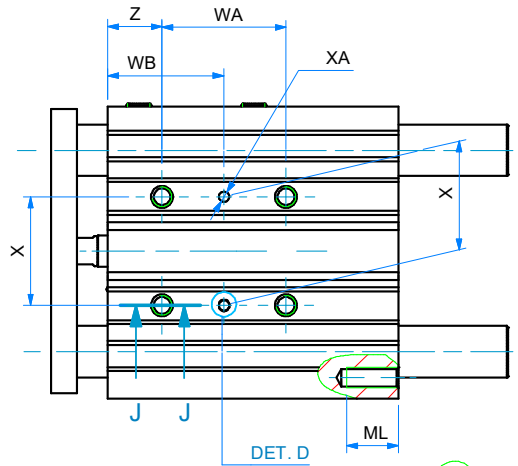
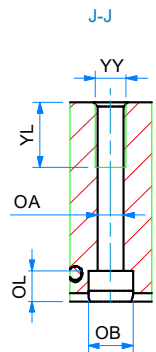
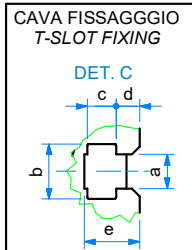
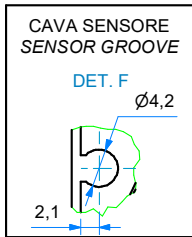
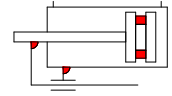

① Vite regolazione ammortizzo - Cushioning adjustment screw

\varnothing	CORSE STANDARD - STANDARD STROKES
016	25 - 30 - 40 - 50 - 75 - 100
020	25 - 30 - 40 - 50 - 75 - 100 - 125 - 150 - 175 - 200
025	25 - 30 - 40 - 50 - 75 - 100 - 125 - 150 - 175 - 200
032	25 - 50 - 75 - 100 - 125 - 150 - 175 - 200
040	25 - 50 - 75 - 100 - 125 - 150 - 175 - 200
050	25 - 50 - 75 - 100 - 125 - 150 - 175 - 200
063	25 - 50 - 75 - 100 - 125 - 150 - 175 - 200

!!!: Le corse intermedie della versione ammortizzata non sono realizzabili (per ulteriori informazioni contattare l'ufficio commerciale)

Intermediate strokes of versions with cushioning are not possible (for further information, please contact our sales department)



DIMENSIONI - DIMENSIONS

CON BOCCOLE IN BRONZO - WITH BRONZE BUSH

ø	16	20	25	32	40	50	63
A+ (corsa-stroke 0÷25)	71	78	78,5	97	97	106,5	106,5
A+ (corsa-stroke >25÷50)	71	86,5	87	127	127	131,5	131,5
A+ (corsa-stroke 75÷200)	71	84,5	85	102	102	118	118
B+	71	78	78,5	84,5	91	97	102
C+	58	62	62,5	62,5	69	69	74
øDA	8	10	10	12	12	16	16
øDB	10	12	16	20	20	25	25
E (corsa-stroke 0÷25)	0	0	0	12,5	6	9,5	4,5
E+ (corsa-stroke >25÷50)	0	8,5	8,5	42,5	36	34,5	29,5
E (corsa-stroke 75÷200)	0	6,5	6,5	17,5	11	21	16
FA	8	10	10	10	10	15	15
FB	5	6	6	12	12	13	13
G	30,5	36,8	42,8	49	55	65	79
GA	11	11,5	11,5	12	15	15	15,5
GB	8	9	10	9	12	12	13,5
H	64	84	94	113	121	149	163
HA	M4	M5	M5	M6	M6	M8	M10
HB	32,5	41,5	46,5	56	60	74	81
HC	32	42,5	47,5	57	61	75	82
J	15	18	21	24	27	32	39
K	15,5	18,8	21,8	25	28	33	40
L	22	24	30	34	40	46	58
MM	M5	M5	M6	M8	M8	M10	M10
ML	12	13	15	16	16	20	22
NN	M5	M5	M6	M8	M8	M10	M10
OA	4,2	5,2	5,2	6,5	6,5	8,5	8,5
OB	8	9,5	9,5	11	11	14	14
OL	4,5	5,5	5,5	7,5	7,5	9	9
P	M5	G1/8	G1/8	G1/8	G1/8	G1/4	G1/4
PA+	40	38,5	37,5	31,5	38	34	38
PB	10	10,5	13,5	16	18	21,5	28
PW	19	25	30	35,5	39,5	47	58
Q	16	18	26	30	30	40	50
R	54	70	78	96	104	130	130
S	25	30	40	45	45	60	70
T	62	81	91	110	118	146	158
U	46	54	64	78	86	110	124
VA	56	72	82	98	106	130	142
VB	38	44	50	63	72	92	110
VC	10,5	12,5	15	19,5	25	33	34
WA (corsa-stroke 0÷75)	44	44	44	48	48	48	52
WA (corsa-stroke 100÷175)	110	120	120	124	124	124	128
WA (corsa-stroke 200)	/	200	200	200	200	200	200
WB (corsa-stroke 0÷75)	27	39	39	45	46	48	50
WB (corsa-stroke 100÷175)	60	77	77	83	84	86	88
WB (corsa-stroke 200)	/	117	117	121	122	124	124
X ±0,02	24	28	34	42	50	66	80
øXA H9	3	3	4	4	4	5	5
XB	3,5	3,5	4,5	4,5	4,5	6	6
XC	3	3	3	3	3	4	4
XL	6	6	6	6	6	8	8
YY	M5	M6	M6	M8	M8	M10	M10
YL	10	12	12	16	16	20	22
Z	5	17	17	21	22	24	24
a	4,4	5,4	5,4	6,5	6,5	8,5	11
b	7,4	8,4	8,4	10,5	10,5	13,5	17,8
c	3,7	4,5	4,5	5,5	5,5	7,5	10
d	3,5	3,6	3,8	4,5	5	5,5	8
e	6,7	8,6	9	10,5	10,5	14,5	19,5



D.E.M. CON CUSCINETTI A RICIRCOLO DI SFERE AMMORTIZZATO

D.A.M. CUSHIONED WITH RECIRCULATING BALL BEARINGS

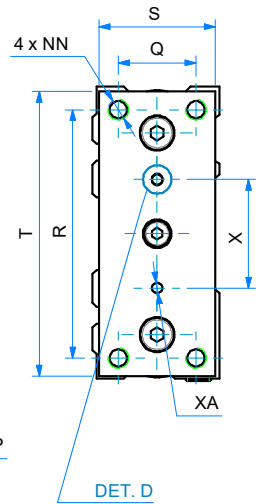
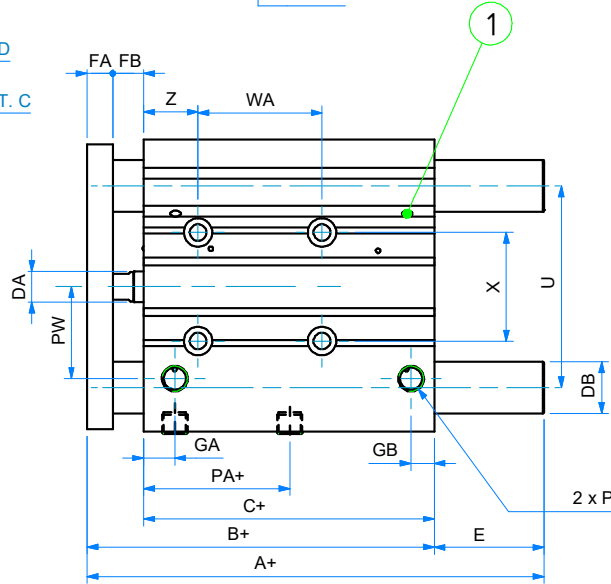
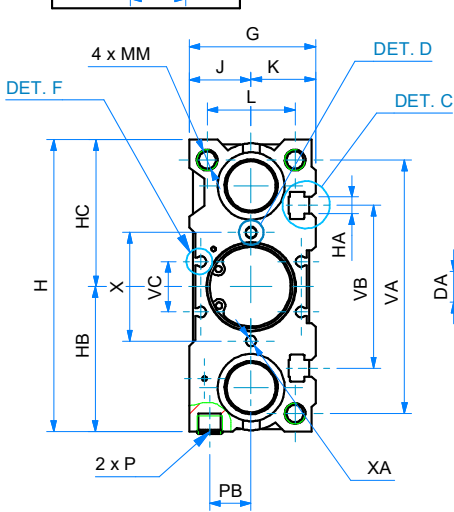
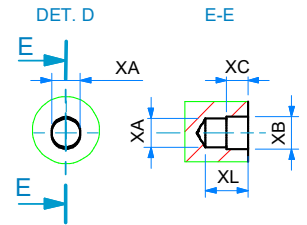
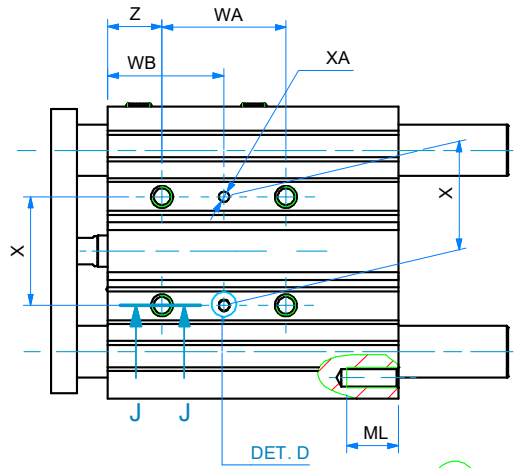
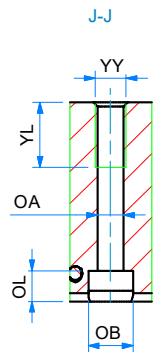
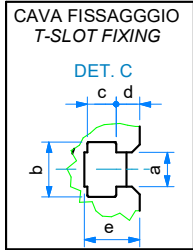
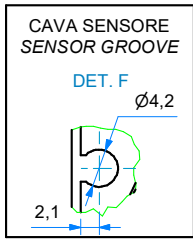
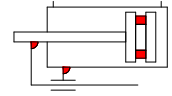

① Vite regolazione ammortizzo - Cushioning adjustment screw

Ø	CORSE STANDARD - STANDARD STROKES
016	25 - 30 - 40 - 50 - 75 - 100
020	25 - 30 - 40 - 50 - 75 - 100 - 125 - 150 - 175 - 200
025	25 - 30 - 40 - 50 - 75 - 100 - 125 - 150 - 175 - 200
032	25 - 50 - 75 - 100 - 125 - 150 - 175 - 200
040	25 - 50 - 75 - 100 - 125 - 150 - 175 - 200
050	25 - 50 - 75 - 100 - 125 - 150 - 175 - 200
063	25 - 50 - 75 - 100 - 125 - 150 - 175 - 200

!!!: Le corse intermedie della versione ammortizzata non sono realizzabili (per ulteriori informazioni contattare l'ufficio commerciale)

Intermediate strokes of versions with cushioning are not possible (for further information, please contact our sales department)



DIMENSIONI - DIMENSIONS

CON CUSCINETTI A RICIRCOLO DI SFERE - WITH RECIRCULATING BALL BEARINGS

\varnothing	16	20	25	32	40	50	63
A+ (corsa-stroke 0÷25)	71	95	100,5	84,5	91	97	102
A+ (corsa-stroke 50)	71	80	85,5	123	123	127,5	127,5
A+ (corsa-stroke 75)	71	80	85,5	98	98	114	114
A+ (corsa-stroke 100)	71	99	99,5	115,5	115,5	159	159
A+ (corsa-stroke >125)	-	104	104,5	118	118	134	134
B+	71	78	78,5	84,5	91	97	102
C+	58	62	62,5	62,5	69	69	74
\varnothing DA	8	10	10	12	12	16	16
\varnothing DB	8	12	14	20	20	25	25
E (corsa-stroke 0÷25)	0	17	22	0	0	0	0
E (corsa-stroke 50)	0	2	7	38,5	32	30,5	25,5
E (corsa-stroke 75)	0	2	7	13,5	7	17	12
E (corsa-stroke 100)	0	21	26	31	24,5	62	57
E (corsa-stroke >125)	-	26	26	33,5	27	37	32
FA	8	10	10	10	10	15	15
FB	5	6	6	12	12	13	13
G	30,5	36,8	42,8	49	55	65	79
GA	11	11,5	11,5	12	15	15	15,5
GB	8	9	10	9	12	12	13,5
H	64	84	94	113	121	149	163
HA	M4	M5	M5	M6	M6	M8	M10
HB	32,5	41,5	46,5	56	60	74	81
HC	32	42,5	47,5	57	61	75	82
J	15	18	21	24	27	32	39
K	15,5	18,8	21,8	25	28	33	40
L	22	24	30	34	40	46	58
MM	M5	M5	M6	M8	M8	M10	M10
ML	12	13	15	16	16	20	22
NN	M5	M5	M6	M8	M8	M10	M10
OA	4,2	5,2	5,2	6,5	6,5	8,5	8,5
OB	8	9,5	9,5	11	11	14	14
OL	4,5	5,5	5,5	7,5	7,5	9	9
P	M5	G1/8	G1/8	G1/8	G1/8	G1/4	G1/4
PA+	40	38,5	37,5	31,5	38	34	38
PB	10	10,5	13,5	16	18	21,5	28
PW	19	25	30	35,5	39,5	47	58
Q	16	18	26	30	30	40	50
R	54	70	78	96	104	130	130
S	25	30	40	45	45	60	70
T	62	81	91	110	118	146	158
U	46	54	64	78	86	110	124
VA	56	72	82	98	106	130	142
VB	38	44	50	63	72	92	110
VC	10,5	12,5	15	19,5	25	33	34
WA (corsa-stroke 0÷75)	44	44	44	48	48	48	52
WA (corsa-stroke 100÷175)	110	120	120	124	124	124	128
WA (corsa-stroke 200)	/	200	200	200	200	200	200
WB (corsa-stroke 0÷75)	27	39	39	45	46	48	50
WB (corsa-stroke 100÷175)	60	77	77	83	84	86	88
WB (corsa-stroke 200)	/	117	117	121	122	124	124
X ±0,02	24	28	34	42	50	66	80
\varnothing XA H9	3	3	4	4	4	5	5
XB	3,5	3,5	4,5	4,5	4,5	6	6
XC	3	3	3	3	3	4	4
XL	6	6	6	6	6	8	8
YY	M5	M6	M6	M8	M8	M10	M10
YL	10	12	12	16	16	20	22
Z	5	17	17	21	22	24	24
a	4,4	5,4	5,4	6,5	6,5	8,5	11
b	7,4	8,4	8,4	10,5	10,5	13,5	17,8
c	3,7	4,5	4,5	5,5	5,5	7,5	10
d	3,5	3,6	3,8	4,5	5	5,5	8
e	6,7	8,6	9	10,5	10,5	14,5	19,5

SERIE

E

